

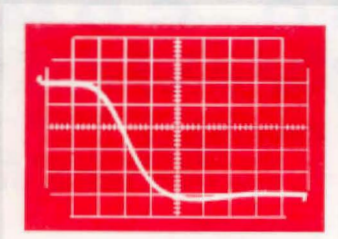

THE GENERAL RADIO

# Experimenter

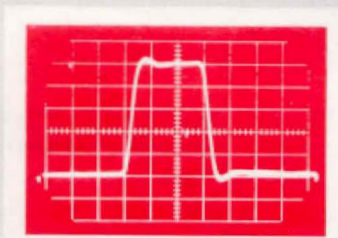
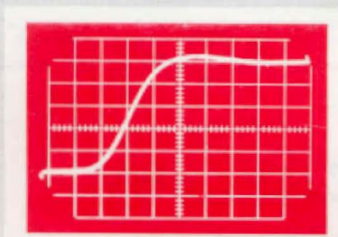

This Issue

VHF

Pulse Generator

Precision

Coaxial Adaptors

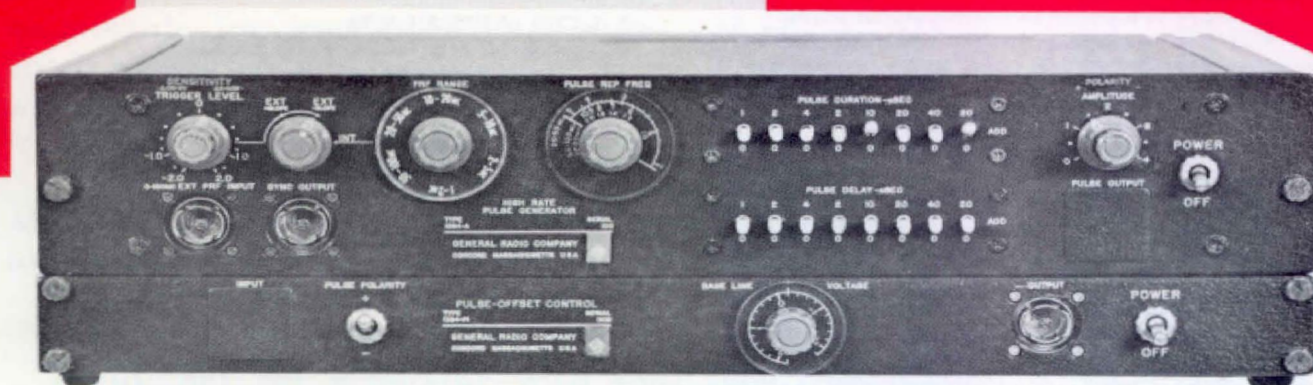

VOLUME 40 • NUMBER 7 / JULY 1966



# the **Experimenter**

© 1966 — General Radio Company, West Concord, Mass., USA

Published monthly by the General Radio Company

## THIS ISSUE

	Page
VHF Pulse Generator.....	3
GR900 Precision Adaptors.....	9

## GENERAL RADIO COMPANY

West Concord, Massachusetts 01781

\* **NEW ENGLAND**

22 Baker Avenue  
West Concord, Massachusetts 01781

\* **METROPOLITAN NEW YORK**

Broad Avenue at Linden  
Ridgefield, New Jersey 07657

**PHILADELPHIA**

Fort Washington Industrial Park  
Fort Washington, Pennsylvania 19034

\* **WASHINGTON and BALTIMORE**

11420 Rockville Pike  
Rockville, Maryland 20852

**ORLANDO**

113 East Colonial Drive  
Orlando, Florida 32801

**SYRACUSE**

Pickard Building, East Molloy Rd.  
Syracuse, New York 13211

**CLEVELAND**

5579 Pearl Road  
Cleveland, Ohio 44129

\* **CHICAGO**

6605 West North Avenue  
Oak Park, Illinois 60302

\* **DALLAS**

2600 Stemmons Freeway, Suite 210  
Dallas, Texas 75207

\* **LOS ANGELES**

1000 North Seward Street  
Los Angeles, California 90038

**SAN FRANCISCO**

626 San Antonio Road  
Mountain View, California 94040

\* **TORONTO**

99 Floral Parkway  
Toronto 15, Ontario, Canada

**MONTREAL**

1255 Laird Boulevard  
Town of Mt. Royal, Quebec, Canada

\* Repair services are available at these offices

GENERAL RADIO COMPANY (OVERSEAS), 8008 Zurich, Switzerland  
GENERAL RADIO COMPANY (U.K.) LIMITED, Bourne End, Buckinghamshire, England  
REPRESENTATIVES IN PRINCIPAL OVERSEAS COUNTRIES





Figure 1. Panel view of the Type 1394-Z High-Rate Pulse Generator, consisting of (top) the Type 1394-A High-Rate Pulse Generator and (bottom) Type 1394-P1 Pulse-Offset Control.

## VHF PULSE GENERATOR

NEW CIRCUITS YIELD HIGH PERFORMANCE AT MODERATE COST

The continuing rapid expansion of digital techniques into the vhf region has created a demand for generators of high-prf, fast-rise-time pulses. General Radio's new vhf pulse generator makes maximum use of standard, economical components in straightforward yet novel circuits, resulting in state-of-the-art performance at a moderate price.

The new TYPE 1394-A High-Rate Pulse Generator meets the growing requirements for test sources for high-speed computers and data-transmission and processing systems. Its important features include:

1. High repetition rate; 1- to 100-MHz range internally generated; dc to 100 MHz with external drive.
2. Fast rise time: 2 nanoseconds.
3. Duty ratios up to 96%.
4. Internal prf generator with excellent frequency stability.
5. Controls for precise synchronization with external clock signals.

6. Calibrated controls for pulse repetition frequency, amplitude, delay, and duration.

Performance of this order is essential in the design and test of high-speed digital systems. In addition to its use in computer development, this pulse generator has many applications in such fields as data transmission, modern radar systems, nuclear instrumentation, and component testing.

Through the development of new circuits, the above features are made available in a pulse generator of comparatively modest price. Both the prf oscillator and the bistable output circuit embody new ideas; the delay functions are performed by lengths of coaxial cable.

A companion instrument, the TYPE 1394-P1 Pulse-Offset Control (page 7), is available for those applications where dc output coupling is required. The combination is the TYPE 1394-Z.

Figure 2 is a simplified block diagram of the generator. A pulse train from the prf oscillator is applied to

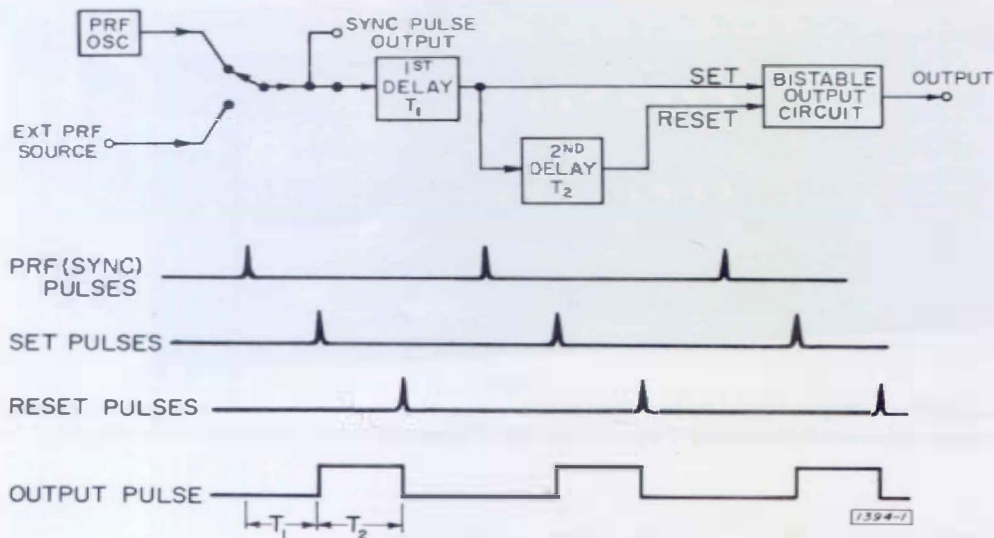

Figure 2. Elementary block diagram with waveforms.

the first delay circuit, which delays the pulses by time  $T_1$ . The delayed pulses are applied to the bistable output circuit as set pulses and also to the second delay circuit, which delays the train further by an amount  $T_2$  to form reset pulses. The first delay is thus the delay between the sync pulse and the leading edge of the output pulse, and the second delay is the duration of the output pulse. On page 5 is a discussion of the individual circuits, illustrating their unique aspects and pointing out their advantages to the user.

### APPLICATIONS

One important application of the TYPE 1394-A High-Rate Pulse Generator is in testing of complementary flip-flops or scalars. Tests of maximum input pulse frequency as a function of pulse duration, amplitude, supply voltage, etc are easily made with this generator. Double- or triple-pulse testing at low repetition rates, on the other hand, although it gives an indication of the maximum frequency at which a digital circuit may operate properly, is not completely adequate. Only sustained operation at the maximum fre-

quency can show the effects of self-biasing due to ac coupling and nonlinearities and also the effects of power dissipation due to rapid switching, both of which may be significant factors in circuit performance.

Another application of the instrument is as a clock-pulse generator for a digital system. Both the precision of setting and the stability of the prf oscillator are quite important in this application.

Many digital devices have the properties of a threshold detector; when a pulse exceeds a certain voltage level, the circuit acts. Threshold circuits can be conveniently tested with the TYPE 1394-A/P1, since the combination of a stepped pulse attenuator and a smooth, precise offset control allows continuous adjustment of pulse level through a range of +6 to -6 volts.

The input circuits include a calibrated trigger-level control and a slope-polarity switch. Sensitivity is better than 0.4 volt, peak-to-peak. Consequently, when the instrument is triggered by an external signal, optimum operation can be obtained over wide ranges of input waveform and voltage



level. This capability is important when the instrument is used as a regenerator in a system.

The circuit configurations were chosen to provide the high performance necessary to meet today's vhf pulse needs and to do so without pushing conventional techniques to the limits, which is never satisfactory from either the cost or the reliability standpoint. These circuits provide two additional advantages that improve on present practice.

The first is freedom from the duty-ratio limits usually imposed by delay-circuit recovery or output-circuit power-dissipation limits. This instru-

ment is very convenient to operate, and it is satisfying to know that the output circuit will operate in any environment and with any combination of control settings without being on the edge of a dissipation limit.

The second advantage is that the instrument has accurately calibrated controls and is stable in operation. Because the settings of the panel controls tell the operator what the generator is doing, he can devote his attention to the system under test with a minimum of attention to the pulse source, and without the necessity of tying up an expensive scope to monitor the pulses.

### CIRCUIT DESCRIPTION

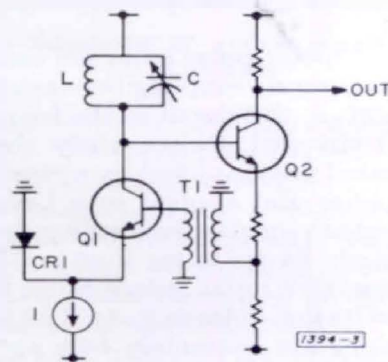

Figure 3. PRF Circuit, simplified circuit diagram.

#### PRF Oscillator\*

The circuit of the prf oscillator is shown in elementary form in Figure 3.

A constant-current source,  $I$ , is switched between diode  $CR1$  and transistor  $Q1$  by a large sinusoidal signal on the base of  $Q1$ . The resulting square wave of collector current drives the LC tuned circuit at its resonant frequency, producing a high-amplitude sinusoidal voltage at the base of  $Q2$ . The collector of  $Q2$  supplies the sinusoidal output voltage. The feedback loop is closed by the application of a fraction of  $Q2$ 's emitter voltage to the base of  $Q1$ , via inverting transformer  $T1$ , which is a wideband one-to-one transformer of the type described by Ruthroff<sup>1</sup>.

The advantages of this circuit configuration are that the simplest resonant circuit is used

for frequency determination and that the amplitude is proportional to the current from the constant-generator current, which is the collector of a transistor used in the automatic amplitude control. Figure 4 shows the variation of oscillator frequency with warmup time and with line voltage.

#### The Delay Function

Pulses propagating through polyethylene-dielectric coaxial cable are delayed by one nanosecond for approximately every 20 cm (7.8 in) of cable length. Since the delays required by this generator are less than 100 nanoseconds, they can be provided by reasonable lengths of cable. The delay circuits consist of lengths of coaxial cable cut for 1, 2, 4, 2, 10, 20, 40, and 20 nanoseconds. These can be switched in or out of the signal path to change the delay in one-nanosecond increments from zero to 99 nanoseconds.

Cable-delay circuits have the advantages of economy, high duty ratio, high prf, and accuracy as compared to the usual lumped-constant delay circuit. The conventional lumped circuit charges a reactance to produce a time delay. The time taken to discharge the reactance before the next delay period can start places a limit on attainable duty ratios. At high prf's the rates of change of energy to and from the reactance become large and make it desirable to use very small inductances or capacitances, introducing inaccuracies due to uncontrolled stray reactances. Attempts to improve prf or

\* Patent Applied For.  
<sup>1</sup> C. L. Ruthroff, "Some Broad-Band Transformers," *Proceedings of the IRE*, August 1959, p 1337 ff.



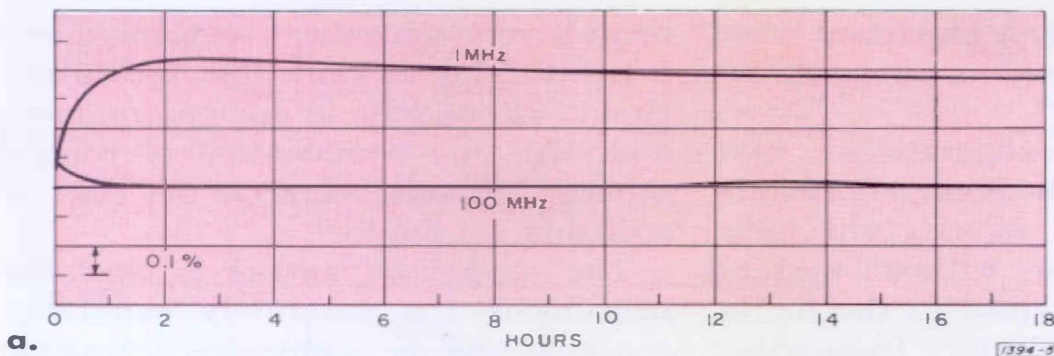

a. (394-5)

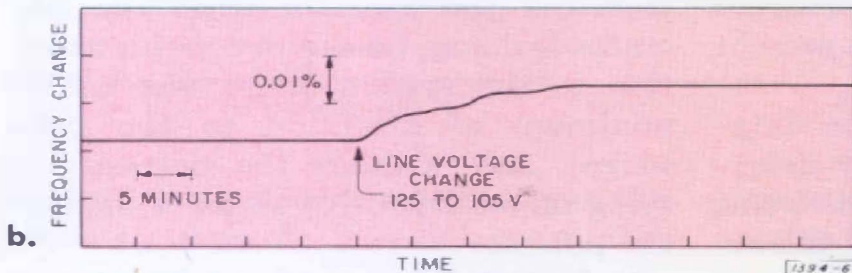

b. (394-6)

**Figure 4. Stability records. (a) Frequency variation on 1- and 100-MHz ranges from cold start. (b) Frequency variation on 100-MHz range due to line-voltage change.**

duty ratio by a decrease in the voltage or current swing on the reactance also result in decreased accuracy, because the error in detection of the charged voltage or current level does not decrease in proportion to the signal swing.

Cable-delay circuits operate on a much different principle from that of the conventional delay circuit, and duty-ratio restrictions are not applicable in the same sense as they are to the latter. The delay of a pulse train in cables may even exceed its period. Accuracy of cable-produced delay depends upon the stability of the cable length and upon the cable dielectric constant. Cable-produced delays are accurately known and are much more stable than those obtainable by conventional circuits operating at very high prf's.

**Pulse Regeneration**

When cables are used for delay, the pulse shape deteriorates as the pulse is propagated along the line and must be restored. Pulse shapes are regenerated at several points in the

system by means of the circuit shown in Figure 5.

Bipolar pulse pairs are used in this generator to allow ac coupling between stages without a dc shift in the signal as the frequency of the signal is changed. Pulses whose shapes have deteriorated are amplified by a class-A broadband amplifier and applied to a bistable tunnel diode, so that the positive input pulses cause the tunnel diode to go to its high-voltage state, and the negative input pulses cause the diode to return to its low-voltage state. The tunnel diode transitions are extremely fast and, as a result, the higher-frequency components of the signal, which were lost in the delay line, are restored. The fast pulse from the tunnel diode is applied to a clipping line, which differentiates the signal to reproduce the desired bipolar pulse.

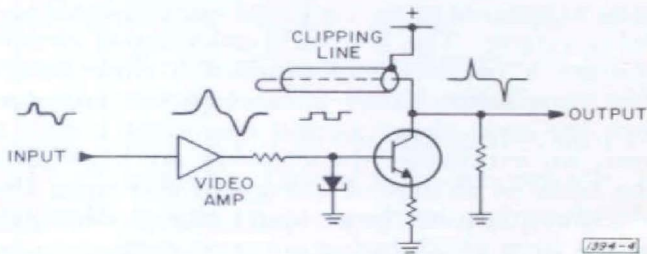

**Figure 5. Pulse-Regeneration Circuit.**

**The Bistable Output Circuit**

Figure 6 is a simplified schematic diagram of the bistable output circuit. The set and reset pulses are applied to the tunnel diode through 100-ohm coaxial cable, and, since the tunnel diode appears as a very low impedance (approximately 5 ohms except for the extremely short time that it is switching between states), the pulse voltages appear almost equally on both bases. The differential amplifier Q3-Q4 amplifies only the signal difference between its bases and not a voltage applied to both bases. Thus, although the tunnel diode voltage is amplified, the set and reset pulses are not and do not appear in the output. This type of connection

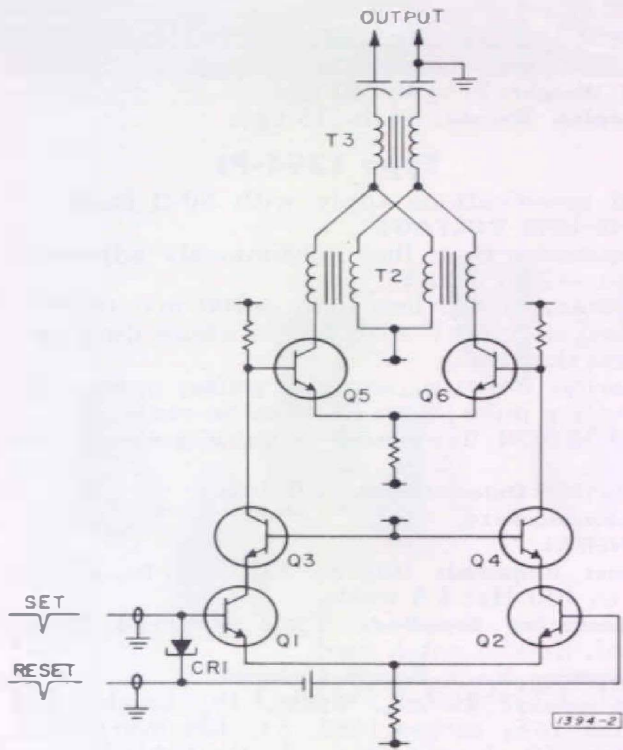

Figure 6. Simplified schematic of output circuit.

greatly reduces the sensitivity of output wave shape to variations in the set or reset pulses.

Q5 and Q6 are grounded-base stages that allow Q3 and Q4 to operate into very low collector impedances, for maximum bandwidth. The grounded-base stages drive a second differential amplifier, Q7 and Q8, which is coupled to the output by transformers T2 and T3.

Transformer T2 is a 2:1 balanced transformer constructed along the lines suggested by Ruthroff.<sup>1</sup> It has an extremely wide bandwidth, from less than 100 kHz to a few hundred MHz. Figure

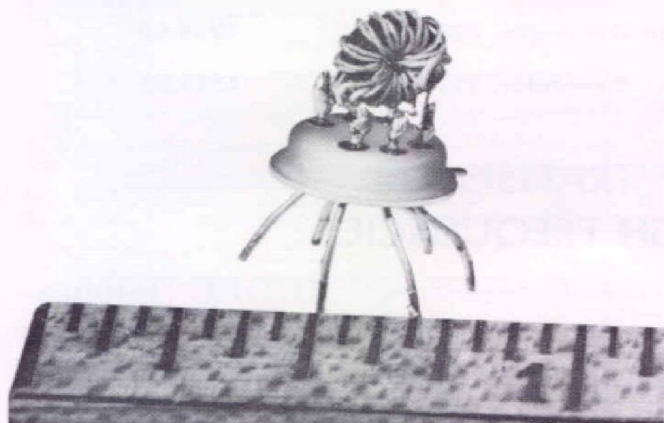

Figure 7. Photograph of output transformer, T2. Size is indicated by scale on the ruler.

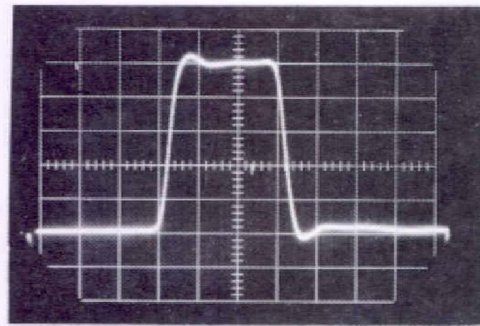

Figure 8. Output-pulse waveform. A 15-ns pulse at 20-MHz repetition rate. Horizontal scale, 5 ns per major division.

7 is a photograph of T2 with its protective cover removed. T3 is a balanced-to-unbalanced transformer.<sup>2</sup> Figure 8 shows the output-pulse waveform. The output circuit includes a precision 50-ohm attenuator, which drops the output from a maximum of four volts to zero in half-volt steps.

#### Pulse-Offset Control

The TYPE 1394-P1 Pulse-Offset Control is a companion instrument to the TYPE 1394-A High-Rate Pulse Generator (see Figure 1). Interconnections are made at the rear of the instruments since both are designed so that all front-panel connectors are easily transferred to the rear panel. The Pulse-Offset Control consists of a peak-voltage detector, reference voltage generator, and a high-gain control-amplifier. It inserts a dc component in the pulse output of the pulse generator so that the base line of the pulse is regulated to be equal to the reference voltage. This combination of instruments meets the needs of those applications that require dc coupling. The pulse-offset voltage is continuously adjustable from -2 to +2 volts.

— J. K. SKILLING

<sup>1</sup> *Ibid.*

<sup>2</sup> Lewis and Wells, *Millimicrosecond Pulse Techniques*, 2nd Edition, Pergamon Press, 1959, p 104 ff.

**Note:** A brief biography of James K. Skilling, author of the foregoing article, appeared in the March 1966 issue of the *Experimenter*. — Editor

## SPECIFICATIONS

### Type 1394-A

#### PULSE REPETITION FREQUENCY

**Internally Generated:** 1.0 MHz to 100 MHz; six ranges in 1-2, 2-5, 5-10 sequence. Continuous coverage,  $\pm 5\%$  of setting. Jitter,  $< 0.1$  ns, peak.

**Externally Controlled:** dc to 100 MHz, 0.4 to 4.0 V, p-to-p, amplitude range plus 10 to 1 attenuator,

(Continued)



**SPECIFICATIONS (Cont'd)**

1 W max. 50 Ω, choice of ± slope, and trigger level from -2 to +2 V.

**SYNCHRONIZING-PULSE CHARACTERISTICS**

**Description:** Bipolar pulses, leading edge of positive pulse is reference.

**Duration:** 4 ns, typical.

**Amplitude:** Approx 250 mV, p-to-p, into 50 Ω.

**Delay (between sync pulse and leading edge of output pulse):** 0 to 99 ns in 1-ns steps, ±2.5% ± 1-ns accuracy. No restriction on ratio delay period. Jitter, <0.1 ns, peak.

**Residual Delay:** 35 ns, typically.

**OUTPUT-PULSE CHARACTERISTICS (all specifications apply to 50-Ω load)**

**Duration:** 4 to 99 ns in 1-ns steps, ±2.5% ± 1-ns accuracy. Jitter, <0.1 ns, peak.

**Rise and Fall Times:** 2.0 ns ±20%.

**Voltage:** Ac coupled. 0 to 4 V in calibrated ½-volt steps. Plus or minus polarity.

**Duty Ratio:** Limited only by rise-plus-fall time. **Overshoot:** 12% typically.

**Drop:** <±10% at maximum duration.

**GENERAL**

**Power Required:** 100 to 125/200 to 250 V; 50 to 400 Hz; 24 W.

**Accessories Supplied:** TYPE CAP-22 Power Cord; spare fuses.

**Mounting:** Rack-Bench Cabinet.

**Dimensions:** Bench, width 19, height 3<sup>15</sup>/<sub>16</sub>, depth 16<sup>3</sup>/<sub>4</sub> inches (485, 100, 425 mm); rack, width 19,

height 3<sup>1</sup>/<sub>2</sub>, depth behind panel 14<sup>1</sup>/<sub>2</sub> inches (485, 89, 370 mm), over-all.

**Net Weight:** 21<sup>1</sup>/<sub>2</sub> lb (10 kg).

**Shipping Weight:** 34 lb (15 kg).

**Type 1394-PI**

(All specifications apply with 50-Ω load)

**BASE-LINE VOLTAGE**

**Amplitude:** Base line continuously adjustable from -2 to +2 V.

**Accuracy:** Error less than ±100 mV (without pulse) ±100 mV with pulses whose duty ratio is less than 90%.

**Polarity:** Positive (negative pulse) or negative (positive pulse) base line can be controlled.

**DISTORTION (introduced in pulse-generator output)**

**Rise-Time Deterioration:** <0.2 ns.

**Drop Increase:** <2%.

**GENERAL**

**Power Required:** 100 to 125/200 to 250 V; 50 to 400 Hz; 4.5 watts.

**Accessories Supplied:** Type CAP-22 Power Cord, coaxial patch cord.

**Mounting:** Rack-Bench Cabinet.

**Dimensions:** Bench, width 19, height 2<sup>1</sup>/<sub>8</sub>, depth 16<sup>3</sup>/<sub>4</sub> inches (485, 54, 425 mm); rack, width 19, height 2<sup>1</sup>/<sub>8</sub>, depth behind panel 14<sup>1</sup>/<sub>2</sub> inches (485, 54, 370 mm), over-all.

**Net Weight:** 12<sup>1</sup>/<sub>4</sub> lb (6 kg).

**Shipping Weight:** 17 lb (8 kg).

Catalog Number	Description	Price in USA
1394-9801	Type 1394-A High-Rate Pulse Generator, Bench Model	\$995.00
1394-9811	Type 1394-A High-Rate Pulse Generator, Rack Model	995.00
1394-9611	Type 1394-PI Pulse-Offset Control, Bench Model	255.00
1394-9621	Type 1394-PI Pulse-Offset Control, Rack Model	255.00
1394-9911	Type 1394-Z High-Rate Pulse Generator, 115 volts Bench Model	1250.00
1394-9912	Type 1394-Z High-Rate Pulse Generator, 115 volts Rack Model	1250.00
1394-9913	Type 1394-Z High-Rate Pulse Generator, 230 volts Bench Model	1250.00
1394-9914	Type 1394-Z High-Rate Pulse Generator, 230 volts Rack Model	1250.00

**MEASUREMENT OF TRANSISTOR PARAMETERS AT HIGH FREQUENCIES**

Users of the TYPE 1607-A Transfer-Function and Immittance Bridge for transistor measurements will be interested in a recent JEDEC standard entitled "A Method for the Measurement of Small-Signal High-Frequency Tran-

sistor Parameters," JEDEC Publication No. 55, March 1966, \$1.10. Copies can be obtained from EIA, Engineering Department, 2001 Eye Street, N.W., Washington, D.C. 20006.





Figure 1. GR900 Precision Adaptors.

## GR900 PRECISION ADAPTORS

The TYPES 900-QSCJ\* and -QSCP\* Adaptors to Type SC are the latest additions to the GR900 series of precision adaptors to military-type connectors. Adaptors previously announced<sup>1</sup> include the TYPES 900-QNJ, -QNP Adaptors to Type N, the TYPES 900-QBJ, -QBP Adaptors to Type BNC, the TYPES 900-QTNJ, -QTNP Adaptors to Type TNC, and the TYPES 900-QCJ, -QCP Adaptors to Type C.

The new TYPES 900-QMMJ and -QMMP Adaptors to OSM/BRM are

for use with the nonmilitary miniature connectors called group A by Brinton<sup>2</sup>. These connectors include those specified as ASM, BRM, ESCAM, MICRO, MOB-50, NPM, OSM, SRM, and STM.

Each adaptor contains a GR900 Precision Coaxial Connector, a specially designed continuous transition between

\* The suffix J indicates that the adaptor is female (contains a jack) and the suffix P indicates that the adaptor is male (contains a plug).

<sup>1</sup> *General Radio Experimenter*, November 1963 and January 1965.

<sup>2</sup> Brinton, J. B., Jr., "Miniature Coaxial Components," *MicroWaves*, February 1965, p 32.

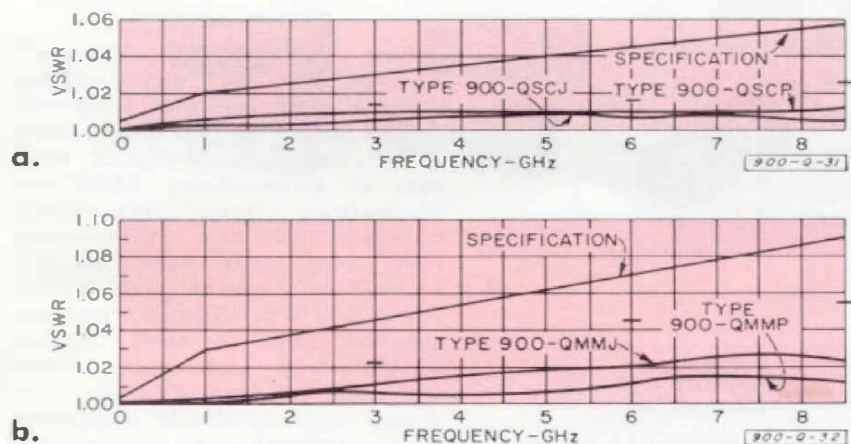

Figure 2. Measured data on sample lots of (a) Types 900-QSCJ and -QSCP Adaptors to SC and (b) Types 900-QMMJ and -QMMP Adaptors to OSM/BRM. Solid curves are averages; bars at 3, 6 and 8.5 GHz are maximums. Measurement error is less than 1/4th of the specifications.

In measurement and standards laboratories, many different types of coaxial connectors are encountered. For maximum utility, a basic line of measuring equipment based on precision connectors must include adaptors to other commonly used types. Recognizing this, General Radio has provided several adaptors from the GR900 Precision Coaxial Connector. We now add two new types, SC and OSM/BRM, described in the following article. We have also included a discussion of the effect of mating dimensions and gaps, which, we hope, will help to answer some of the questions that have been asked about VSWR errors from these sources.

**PRECISION ADAPTOR APPLICATIONS**

By means of precision adaptors, the excellent performance of GR900 coaxial standards and instruments can be extended to measurements on devices equipped with other types of connectors.

**Slotted-Line Measurements**

With a set of GR900 Precision Adaptors in combination with a TYPE 900-LB Precision Slotted Line one can make accurate impedance measurements through 14 different coaxial connectors as shown in Figure 3: the military types N, BNC, TNC, C, and SC, jacks and plugs; the OSM/BRM types or equivalents, jack and plug; the general-purpose GR874; and the precision GR900. Figure 4a shows the specified performance of the various adaptor-slotted-line combinations; typical vswr is about half that specified, as illustrated in Figure 4b for a Type N combination.

line sizes, and a low-vswr version of the applicable (jack or plug) SC or OSM/BRM connector. The vswr performance of these adaptors is shown in Figure 2.

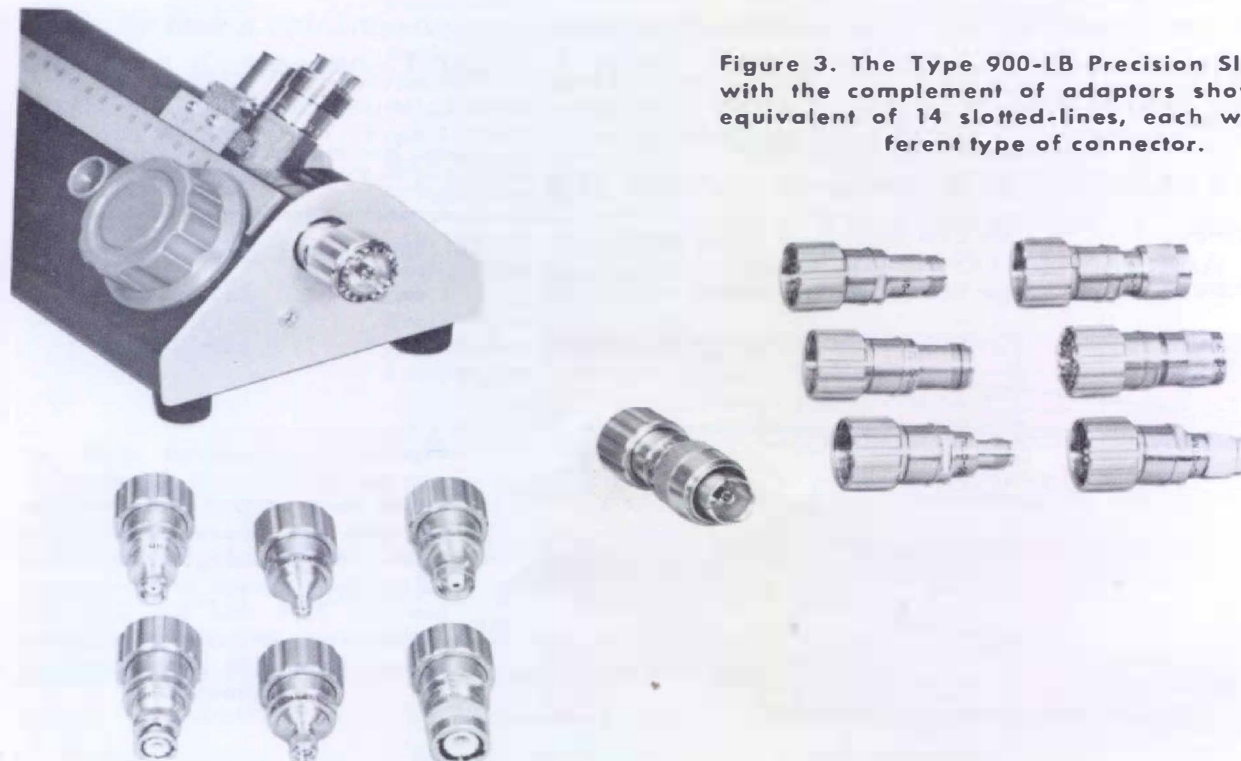

**Figure 3. The Type 900-LB Precision Slotted Line with the complement of adaptors shown is the equivalent of 14 slotted-lines, each with a different type of connector.**



Figure 4. (a) Specified residual VSWR of the Type 900-LB Precision Slotted Line in combination with various GR900 Precision Adaptors. (b) Typical data on a sample lot of the slotted line, Type-N-jack-adaptor combination. Bars above curve at 1, 3, 5, 7 and 8.5 GHz are maximum VSWR's; bars below curve are averages.

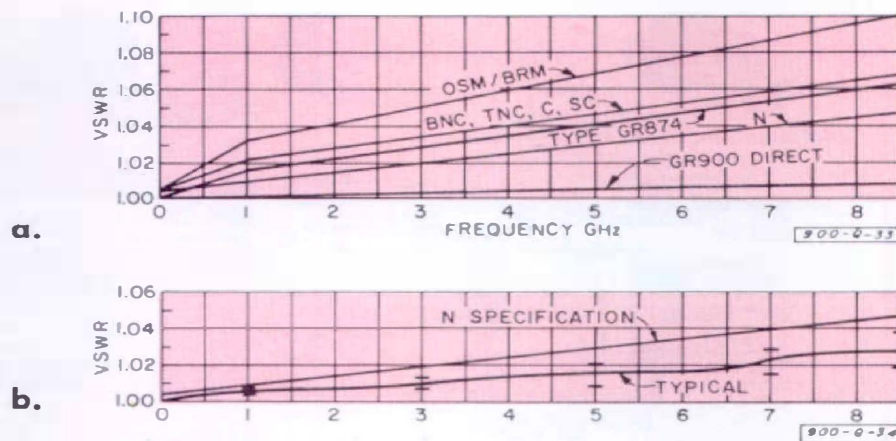

**Matched Terminations**

Similarly, the precision adaptors in combination with a TYPE 900-W50 50-ohm Standard Termination provide low-vswr terminations for the various connector types. Figure 5 shows the specified performance.

**Advantages**

There are two important advantages to utilizing precision adaptors as described above: accuracy and economy. The accuracy of measurement through each connector type is usually better than that provided by slotted lines or terminations designed specifically for the connector type of interest. This is because (1) the TYPE 900-LB Slotted Line and the TYPE 900-W50 Termination exhibit very low residual vswr's, which can be accurately calibrated at the GR900 Connector reference planes;

- (2) the continuous transitions in the adaptors are nearly reflectionless, and
- (3) connectors of the series being adapted to are optimally designed.

The advantage of economy is obvious: the cost of one slotted line, one termination and several adaptors is far less than the cost of individual slotted lines and terminations for each connector type.

**MATING DIMENSIONS**

When two GR900 Precision Connectors are mated, the vswr introduced by one of the connectors is not influenced by variations in the dimensions of the second connector. On the other hand, when two Type N connectors are mated, the vswr introduced by the jack connector is directly dependent on the diameter of the pin of the plug-connector inner conductor against which the jack inner-conductor fingers rest. Similarly, the vswr introduced by the

Figure 5. (a) Specified VSWR of the Type 900-W50 50-ohm Standard Termination in combination with various GR900 Precision Adaptors. (The 900-W50/900-Q874 combination is not shown since nearly equivalent performance can be obtained directly with the Type 874-W50BL Termination.) (b) Typical data on a sample lot of the termination, Type N plug adaptor combination. Bars above curve at 1, 3, 5, 7, and 8.5 GHz are maximum VSWR's; bars below curve are averages.

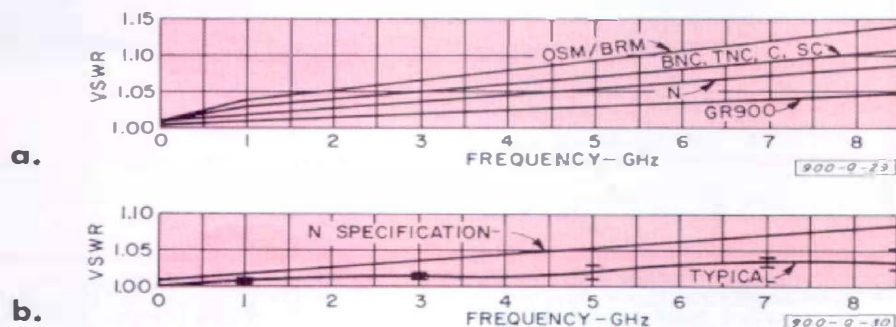

for use with **TYPE N**



**TYPE 900-QNJ**



**TYPE 900-QNP**

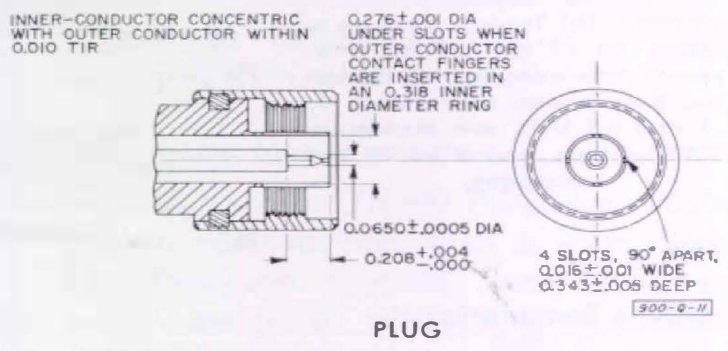
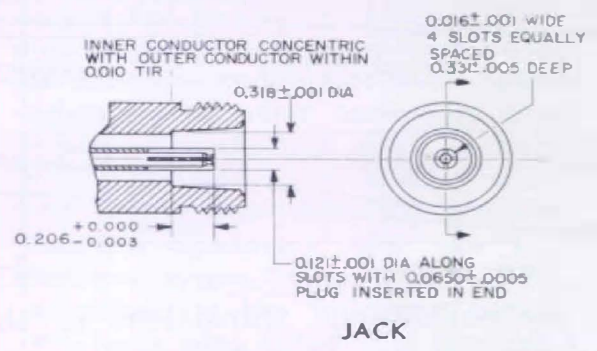

for use with **TYPE BNC**



**TYPE 900-QBJ**



**TYPE 900-QBP**

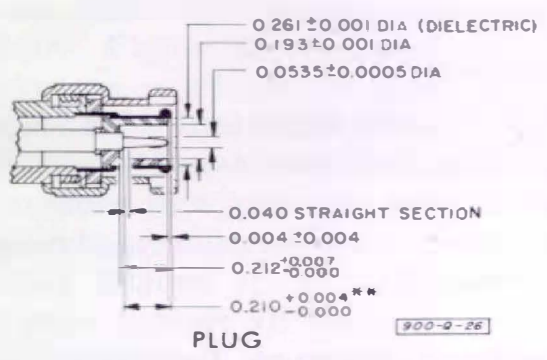
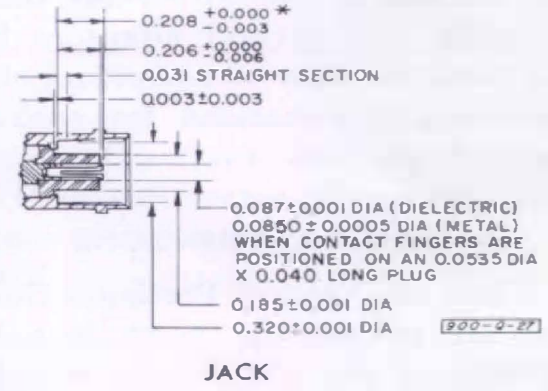

for use with **TYPE TNC**



**TYPE 900-QTNJ**



**TYPE 900-QTNP**

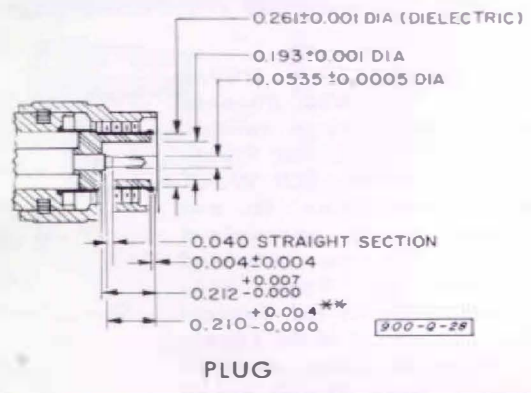
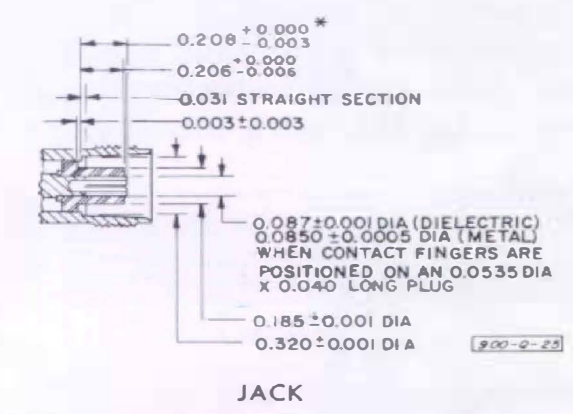

\* Inner conductor has 4 equally spaced slots 0.008 ± 0.001 wide by 0.187 ± 0.005 deep.  
 \*\* Outer conductor has 6 slots 60° apart, 0.015 ± 0.001 wide by 0.235 ± 0.003 deep; inner diameter in region of contact-fingers is 0.2650 ± 0.0005 when fingers are inserted in a 0.3200 inner-diameter ring.



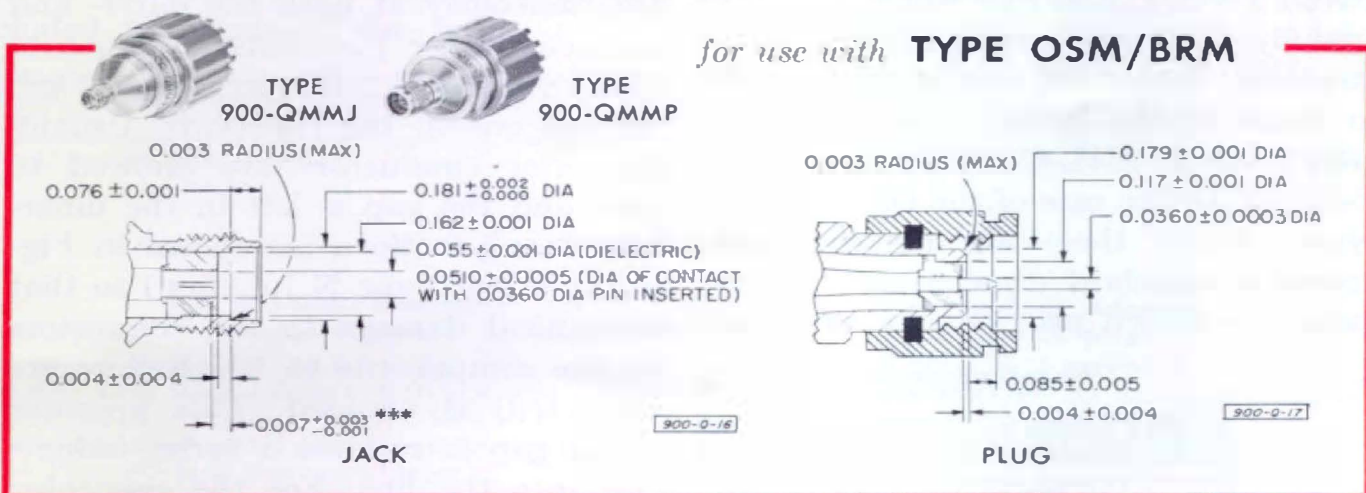
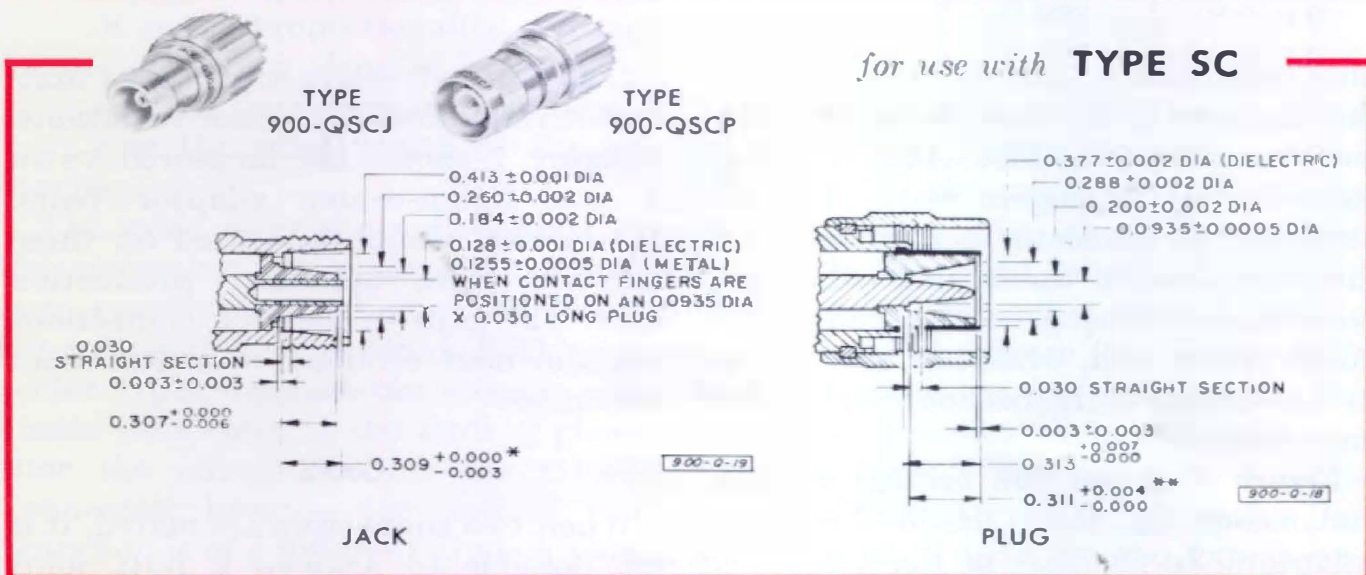
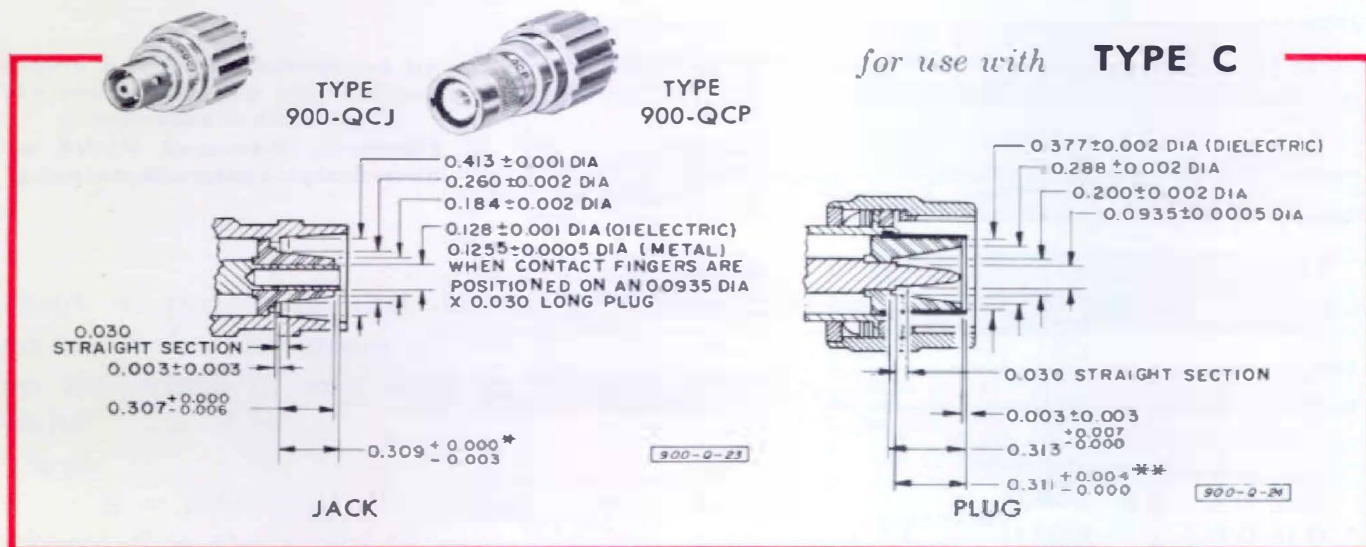

\* Inner conductor has 4 slots, equally spaced, 0.012 ± 0.001 wide by 0.210 ± 0.005 deep.  
 \*\* Outer conductor has 6 slots, 60° apart, 0.016 ± 0.001 wide by 0.255 ± 0.005 deep; inner diameter in region of contact-fingers is 0.3820 ± 0.0005 when fingers are inserted in a 0.413 inner-diameter ring.  
 \*\*\* Inner conductor has 4 equally spaced slots 0.008 ± 0.001 wide by 0.078 ± 0.005 deep.

**Figure 6. Critical mating dimensions of low-VSWR connectors used with the GR900 Connector on the precision adaptors. (All dimensions are in inches.)**

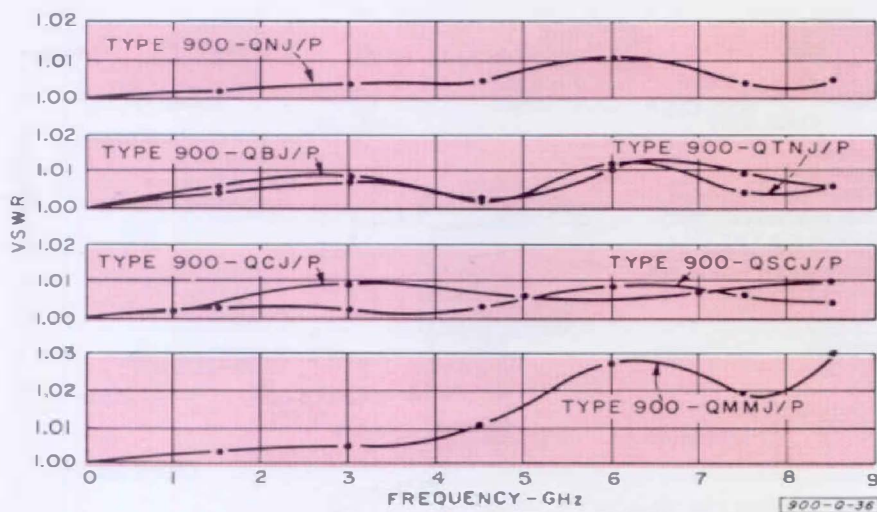

Figure 7. Measured VSWR of near-design-center adaptor pairs.

plug connector is directly dependent on the diameter of the shoulder in the jack outer conductor against which the plug outer-conductor fingers rest. This dependence of connector performance on the dimensions of the mating connector is common to most general-purpose connector series, and, when low vswr's are to be specified, it becomes of major importance.

Figure 6 shows the critical mating dimensions of the GR900 Precision Adaptors. In the case of the Types N, BNC, TNC, C and SC, which are covered by military specifications, the dimensions shown are closely equivalent to those in the latest military standards such as MIL-C-23329 and MIL-C-39012. In the case of the OSM/BRM types, where there are no generally accepted standard dimensions, the dimensions shown provide low vswr as

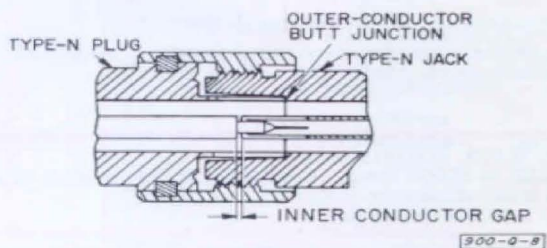

Figure 8. Gap in Type N connector junction.

well as nondestructive mechanical mating with all known connector variations.

Figure 7 shows the measured vswr of near-design-center adaptor pairs. The GR900 Connectors used on these adaptors were standard production units. The gaps in the UG connections (see the next section) were less than one mil.

### GAPS

When two connectors are mated, it is not possible to achieve a butt joint simultaneously at both the outer- and inner-conductor junctions. Because of axial mechanical tolerances, a gap will exist at one of the junctions. Usually the outer conductors are allowed to butt, and the gap is left in the inner-conductor junctions (as shown in Figure 8 for the Type N junction) so that mechanical damage to the connectors (or the components to which they are connected) is avoided. This presence of the gap introduces a series inductance into the line. For the connector types of interest, the vswr resulting from this residual inductance is a linear function of frequency and of the axial dimension of the gap. The con-



Figure 9. VSWR's introduced by the maximum gap dimensions, *g*, indicated in the table.

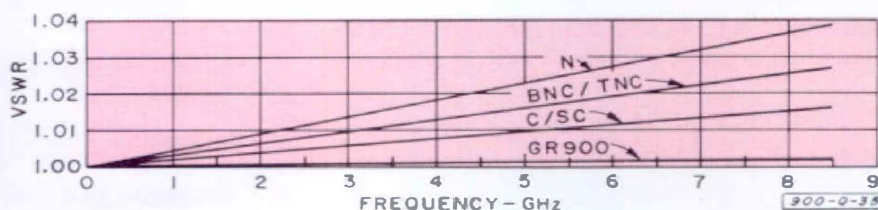

stant of proportionality is dependent on the radial dimension of the gap and on the width of any slots in the gap walls<sup>3</sup>.

Thus,

$$S = Kfg$$

where: *S* is the vswr in per cent,

*K* is the proportionality constant for the connector series of interest,

*f* is the frequency in GHz, and

*g* is the axial length of the gap in mils.

The table gives the values of *K* for the connector types covered by military specifications. Values of *K* are not included for the OSM/BRM connector types, because the steps in conductor diameters at the mating planes alter the effect, nor for the GR874 Connector, because the mating configuration is of a different kind. A value of *K* for the GR900 Connector is included to illustrate the improvement

<sup>3</sup> MacKenzie, T. E., and Sanderson, A. E., "Some Fundamental Design Principles For the Development of Precision Coaxial Standards and Components," *IEEE Transactions on Microwave Theory and Techniques*, Vol MTT-14, No 1, January 1966, p 29-39.

gained through the use of precision connectors.

Connector Type	<i>K</i>	Spread in <i>g</i> (mils)
N	0.051	2.0-9.0
BNC, TNC	0.035	2.0-9.0
C, SC	0.021	2.0-9.0
GR900	0.008	0.8-3.2

The value of *K* is based on nominal values for the radial dimension of the gap and for the width of the slots in the gap walls. The spread in *g* is the spread in the axial length of the gap that results from the critical mating dimensions of Figure 6. Figure 9 is a plot of vswr versus frequency for the maximum *g* indicated in the table.

For a Type N junction with a nominal gap (*g* = 5.5 mils), the vswr introduced at 7 GHz by the gap is approximately 1.02. For a GR900 junction with a nominal gap (*g* = 2.0 mils), the corresponding vswr at 7 GHz is approximately 1.001.

— T. E. MacKenzie

## SPECIFICATIONS

### Type 900-QSCJ Adaptor (contains SC jack)

**Frequency Range:** DC to 8.5 GHz.  
**VSWR:** Less than  $1.005 + 0.015 \times f_{\text{GHz}}$  to 1 GHz;  $1.015 + 0.005 \times f_{\text{GHz}}$ , 1 to 8.5 GHz.  
**Electrical Length:**  $5.03 \pm 0.05$  cm to the end of the Type SC jack inner conductor.  
**Voltage:** 1000 V peak.  
**Power (Average):** 7 kW up to 1 MHz;  
 $7 \text{ kW} / \sqrt{f_{\text{GHz}}}$  above 1 MHz.  
**Dimensions:** Length, 2 inches (51 mm); maximum diameter,  $1\frac{1}{16}$  inches (27 mm).  
**Net Weight:**  $3\frac{1}{2}$  ounces (100 grams).

### Type 900-QSCP Adaptor (contains SC plug)

Same as Type 900-QSCJ except:  
**Electrical Length:**  $5.60 \pm 0.05$  cm to the end of the Type SC plug outer conductor.  
**Dimensions:** Length,  $2\frac{1}{8}$  inches (54 mm).

### Type 900-QMMJ Adaptor (contains OSM/BRM jack)

**Frequency Range:** DC to 8.5 GHz.  
**VSWR:** Less than  $1.005 + 0.025 \times f_{\text{GHz}}$  to 1 GHz;  $1.022 + 0.008 \times f_{\text{GHz}}$ , 1 to 8.5 GHz.

(Continued)

**GENERAL RADIO COMPANY**  
WEST CONCORD, MASSACHUSETTS 01781

DO WE HAVE YOUR CORRECT NAME AND ADDRESS—name, company or organization, department, street or P.O. box, city, state, and zip code? If not, please clip the address label on this issue and return it to us with corrections, or if you prefer, write us; a postcard will do.

**S P E C I F I C A T I O N S (cont'd)**

**Electrical Length:** 4.67 ±0.05 cm to the outer conductor junction.

**Dimensions:** Length, 1 7/8 inches (48 mm); maximum diameter 1 1/16 inches (27 mm).

**Net Weight:** 2 1/2 ounces (70 grams).

**Type 900-QMMP Adaptor**  
(contains OSM/BRM plug)

Same as Type 900-QMMJ except:  
**Electrical Length:** 4.78 ±0.05 cm to the outer conductor junction.

<i>Catalog Number</i>	<i>Description</i>	<i>Price in USA</i>
0900-9713	Type 900-QSCJ Adaptor	\$75.00
0900-9813	Type 900-QSCP Adaptor	85.00
0900-9723	Type 900-QMMJ Adaptor	75.00
0900-9823	Type 900-QMMP Adaptor	80.00

**GENERAL RADIO COMPANY**  
WEST CONCORD, MASSACHUSETTS 01781